

GRAND PIANO COVERS

These quality covers are sewn in our modern shop using only the finest of materials. Covers are available in Black Mackintosh. (A combination of heavy drill cloth bonded to a soft kasha flannel backing.) On a special order basis, covers can be made from our heavy duty padded material. Please call for pricing.



MISCELLANEOUS GRAND COVERS

27R 4'6"	All makes	Each
27R 4'8"	All makes	Each
27R 4'10"	All makes	Each
27R 5'0"	All makes	Each
27R 5'4"	All makes	Each
27R 5'6"	All makes	Each
27R 5'10"	All makes	Each
27R 6'0"	All makes	Each
27R 6'8"	All makes	Each

BOSTON GRAND COVERS

27BS 5'1"	—	Each
27BS 5'4"	GP-163	Each
27BS 5'10"	GP-178	Each
27BS 6'4"	GP-193	Each
27BS 7'1"	GP-215	Each

BALDWIN GRAND COVERS

27B 5'2"	Style M	Each
27B 5'8"	Style R	Each
27B 6'3"	Style L, C, K	Each
27B 7'0"	Style F	Each
27B 9'0"	Style D	Each

KAWAI GRAND COVERS

27KW 4'9"	Style GM-1	Each
27KW 5'1"	Style GE-1	Each
27KW 5'4"	Style RX-1	Each
27KW 5'10"	Style RX-2, & GE-3	Each
27KW 6'1"	Style RX-3	Each
27KW 6'5"	Style RX-5, & RX-A	Each
27KW 7'0"	Style RX-6	Each
27KW 7'6"	Style RX-7	Each
27KW 9'1"	Style EX	Each

KIMBALL GRAND COVERS

27KI 4'5"	Style B	Each
27KI 5'0"	Style D	Each
27KI 5'7"	Style G	Each
27KI 6'5"	Style L	Each
27KI 8'9"	Style M	Each

WM. KNABE & SONS COVERS

27KN 5'1"	Style 400	Each
27KN 5'4"	Style 405	Each
27KN 5'8"	Style 410	Each
27KN 6'4"	Style 415	Each
27KN 7'6"	—	Each
27KN 9'0"	Style D	Each

MASON & HAMLIN COVERS

27MH 5'4"	Style B	Each
27MH 5'8"	Style A	Each
27MH 6'2"	Style AA	Each
27MH 7'0"	Style BB	Each
27MH 9'0"	Style CC Concert	Each

STEINWAY GRAND COVERS

27S 5'1"	Style S	Each
27S 5'7"	Style M	Each
27S 5'10-1/2"	Style L	Each
27S 6'4-1/2"	Style A	Each
27S 6'11"	Style B	Each
27S 9'0"	Style D Concert	Each

YAMAHA GRAND COVERS

27Y 4'11"	—	Each
27Y 5'3"	Style G1B	Each
27Y 5'8"	Style G2D	Each
27Y 6'1"	Style G3D or C3	Each
27Y 6'7"	Style G5D or C5	Each
27Y 6'11"	Style C6	Each
27Y 7'6"	Style C7	Each
27Y 9'0"	Style CF	Each

YOUNG CHANG COVERS

27YC 4'11"	Style G150	Each
27YC 5'2"	Style G157	Each
27YC 5'9"	Style G175	Each
27YC 6'1"	Style G185	Each
27YC 7'0"	Style G213	Each
27YC 9'0"	Style G275	Each

SPECIAL GRAND COVERS (not stocked)

Special covers can be made to specifications, for complete information see below.

PARTICULARS REQUIRED FOR ORDERING

These covers can be made from black mackintosh or black quilted material.

A) Join up a paper and trace a pattern around the entire top of grand. Extreme outside dimensions.

B) Trace a pattern of cheek from under top to bottom of cheek.

C) Send Manufacturer's name, serial number & style. Also give overall measurement from front of keys to extreme end.

Less 10% on all covers when six or more are purchased at one time.

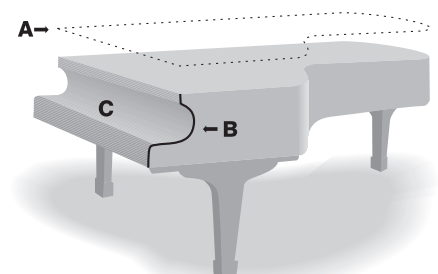

VERTICAL COVERS

UPRIGHT PIANO COVERS

Closed Back

- 23-CB4'0" Each
- 23-CB4'2" Each
- 23-CB4'4" Each
- 23-CB4'6" Each
- 23-CB4'8" Each
- 23-CB4'10" Each

STUDIO UPRIGHT PIANO COVERS

Closed Back

- 23M-CB3'7" Each
- 23M-CB3'8" Each
- 23M-CB3'10" Each

SPINET PIANO COVERS

Closed Back

- 23A-CB3'0" Each
- 23A-CB3'4" Each



BENCH COVERS

Our bench covers are made of the same high quality Mackintosh material described on page 7. They are ideal for use on piano & organ benches in salesrooms, where benches are subject to heavy use. Also for showrooms, schools, and auditoriums. We can manufacture ANY bench size desired, simply specify exact size of bench. If bench has a contour, it is necessary that we have a paper pattern of the top.

All benches have a 7" drop on sides. Any size.

No. 7925 Bench cover. Each



CUSTOM ORGAN COVERS - WE DO NOT STOCK ORGAN COVERS. ALL ARE MADE TO ORDER. WE MAINTAIN A LARGE FILE OF DIMENSIONAL INFORMATION ON MANY ORGANS. WHEN POSSIBLE, SUPPLY MAKE & MODEL NUMBER AND DIMENSIONS PER THE SKETCH BELOW. PRICING WILL BE SUPPLIED UPON REQUEST.

TONE CABINET COVERS - SEND DIMENSIONAL INFORMATION OR MANUFACTURER'S NAME AND MODEL NUMBER, PRICING WILL BE SUPPLIED UPON REQUEST.

INDICATE THE FOLLOWING DIMENSIONS

- AB** Height (without music desk)
- BC** Width
- CD** Depth of top
- AF** Depth of console to front of keyboard
- EF** Distance from top of side cheek at extreme front of Console to floor
- FG** Distance along floor from point below corner of extreme front of Console to rear of bench
- HI** Height of bench
- GH** Width of bench

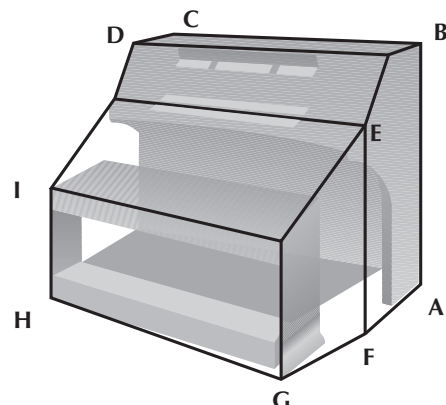

PIANO COVERS

PADDED GRAND COVERS

Protects grand pianos in assembly halls, etc. Constructed of heavy-duty black close-weave duck, padded with cotton filling, flannel lined and quilted in 4" diamond pattern with nylon thread. Water resistant. This is not a commercial padding material, but is made exclusively to our specifications.



AVAILABLE IN THE FOLLOWING SIZES WITHOUT D-RINGS OR STRAPS:

- No. 48-5'2" Grand Cover. Each
- No. 48-5'8" Grand Cover. Each
- No. 48-6'0" Grand Cover. Each
- No. 48-6'3" Grand Cover. Each
- No. 48-6'7" Grand Cover. Each
- No. 48-7'0" Grand Cover. Each
- No. 48-7'5" Grand Cover. Each
- No. 48-9'0" Grand Cover. Each

AVAILABLE IN THE FOLLOWING SIZES WITH ROPE TIES:

- No. 48A-5'2" Grand Cover. Each
- No. 48A-5'8" Grand Cover. Each
- No. 48A-6'0" Grand Cover. Each
- No. 48A-6'3" Grand Cover. Each
- No. 48A-6'7" Grand Cover. Each
- No. 48A-7'0" Grand Cover. Each
- No. 48A-7'5" Grand Cover. Each
- No. 48A-9'0" Grand Cover. Each

**Also available with 3 straps and "D" rings for locking cover to pianos. Please inquire about price and availability.

PADDED UPRIGHT COVERS

Constructed of heavy-duty black close-weave duck, padded with cotton filling. Flannel lined and quilted in 4" diamond pattern with nylon thread. Fitted with slits in back for hand holds. Closed Backs.

- No. 4-4'10" - Uprights. Each
- No. 4-4'6" - Uprights. Each
- No. 4-4'2" - Uprights. Each
- No. 3-3'10" - Studio Uprights. Each
- No. 3-3'8" - Studio Uprights. Each
- No. 1-3'4" - Spinets. Each
- No. 1-3'0" - Spinets. Each



PADDED MOVER'S COVER FOR GRAND PIANOS (padded long side only)

For use with a Grand skidboard to assure protection of the long sides. Constructed of black heavy close-weave duck, water resistant, and lined with canton flannel. The long side is well padded with cotton padding so that the grand may be tipped. Furnished with two strong ropes.

- No. 49 - Grands up to 7'0". Each
- No. 49A - Grands 7'0" to 9'0". Each



MOVER'S ACCESSORIES

PADDED ORGAN / MOVER'S COVERS

Now available from our own shop, the finest quality heavy-duty padded mover's covers. Assures protection in delivery. Constructed of heavy-duty close-weave duck, padded with cotton filling, flannel lined and quilted in a 4" diamond pattern. Water resistant. This is not a commercial padding material, but is made exclusively to our specifications.

No. 852 - For all spinet model organs. Each

No. 853 - For all console full pedal organs. Each

No. 854 - For all concert size organs. Each

No. 855 - Pedal Board Cover. Each



BENCH COVER

Eliminates the time and expense of wrapping legs and padding tops of piano benches.

No. 827 - Canvas Bench Cover. Each



LOADING PADS

Heavy dark blue drill on one side, light blue on the other. Filled with burlap-kersey (jute kersey needled into burlap base) for superior padding. Securely quilted in 3" squares with heavy thread in over 550 small pillows. The small squares prevent tears from spreading, and helps when folding around furniture. Heavy binding all around for extra wear; bar-tacked at each corner. Size listed is cut size before quilting.

No. 814 - Size 72"x 80". Each



STAIR ROLLER

This device makes it easy to move a piano over steps and edges of porch or van. Eliminates damage to piano & property from dragging. Durable steel construction with smooth-action roller.

No. 871 - 21-1/2" Roller. Each

